

# PKZ 2 System – For Optimum Motor and System Protection



## xStart

The complete range of contactors, efficient motor-starters and controlled drives for the motor circuit. New simple to install solutions based on clever communication.

Contactors DIL

**Motor-protective circuit-breakers PKZ**

Motor-starters MSC

Softstarters DS4

Drives

Rapid Link

Technical Paper  
Dipl.-Ing. Wolfgang Esser

**MOELLER** 

We keep power under control.

For Immediate Delivery call [KMParts.com](http://KMParts.com) at (866) 595-9616

Dipl.-Ing. Wolfgang Esser  
 Head of Product Support  
 BU Circuit-Breakers, Motor Starters & Drives  
 Moeller GmbH, Bonn

**PKZ 2 System – For Optimum Motor and System Protection –**

- System Description and Application Notes -

Motor and system protection systems for currents up to 40 A are available in the switchgear market with a wide range of alternatives in terms of technology and price. The top of the range devices presented here are primarily used in systems that place demanding requirements on the availability of equipment in switchgear systems for the chemical and pharmaceutical industry, mining installations, and in systems in the petroleum and raw materials industry. These installations frequently operate with the higher operational voltages 500 and 690 V, together with particularly high short-circuit levels.

In South Africa, for example, the system is used for 525 V systems, and in China for the demanding requirements of infrastructure supply. In America, customers value the system's rugged design and its large creepage and clearance distances. Apart from its outstanding electrical capabilities, the PKZ 2 product system presented offers some interesting additional components with unique selling points that enable the creation of distinctive solutions and ensure convenient handling in switchgear assemblies for remote monitoring and control. A particular strength of this system is without doubt its tried and trusted use

since 1989 in the harshest industrial environments. The PKZ 2 has made a considerable contribution to Moeller's market leadership in motor-protective circuit-breakers. Due to its outstanding capabilities the PKZ 2 product system (Figure 1) is to be further maintained and produced together with the more recent "xStart motor starter" product system from Moeller. The new xStart system [1, 2] primarily covers the higher volume and more cost-sensitive application fields with a very good level of quality.

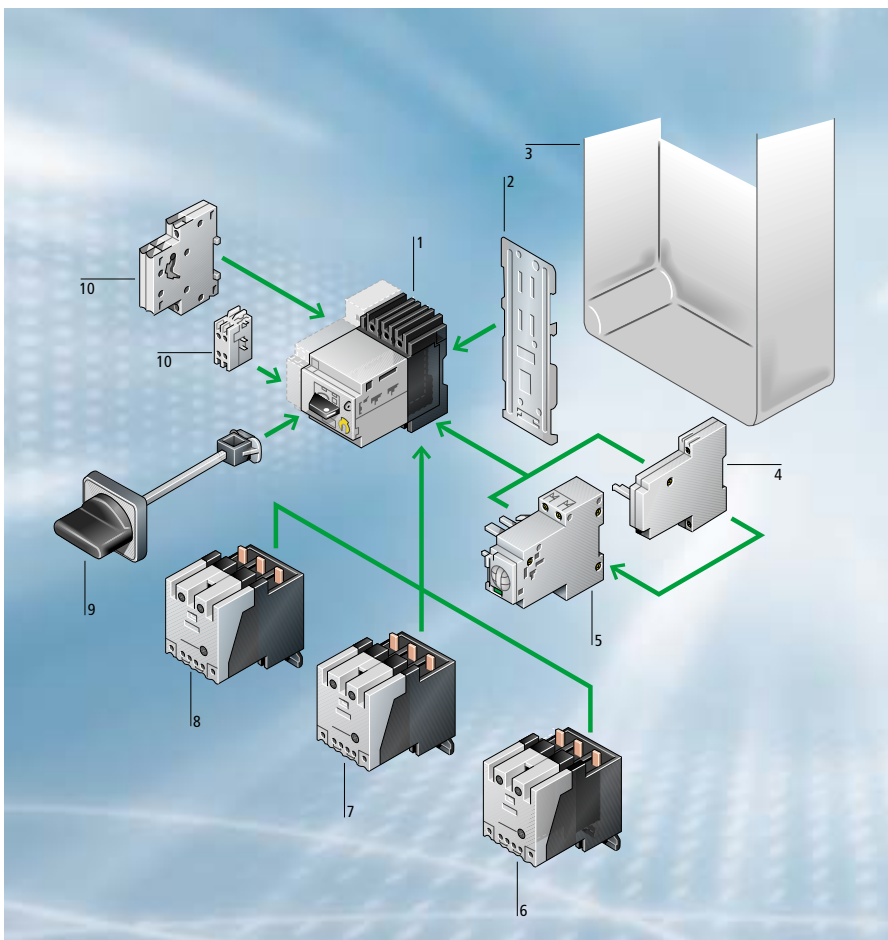

Figure 1:

Key

- 1 Motor-protective circuit-breaker / system protective circuit-breaker
- 2 Clip plate
- 3 Insulated enclosure
- 4 Voltage release
- 5 Remote operator
- 6 Contact module
- 7 High-capacity contact module
- 8 Current limiter
- 9 Door coupling handle IP 65
- 10 Auxiliary contact

## Contents

	Page
<b>Introduction</b>	2
<b>Contents</b>	3
<b>Motor-protective circuit-breaker or circuit-breaker?</b>	4
<b>Motor or system protection</b>	4
<b>Motor-protective circuit-breaker in an individual enclosure, the smallest switchgear assembly</b>	8
<b>Occasional operational switching</b>	9
<b>Occasional switching with remote operators</b>	9
<b>Overload protection</b>	12
<b>Short-circuit protection</b>	12
• Inherent stability of the circuit-breaker	13
<b>Controlling particularly high short-circuit currents with <i>CL-PKZ2</i> current limiters</b>	15
<b>Separate short-circuit protection and overload protection?</b>	17
<b>Pluggable overcurrent and short-circuit releases</b>	18
<b>Alternatives and combinations for motor protection</b>	19
<b>Remote tripping, with voltage-dependent releases</b>	19
<b>Informative signalling</b>	20
<b>High-frequency operational switching with contactors or contact modules</b>	20
• The current limiting effects of high-capacity contact modules	21
<b>Mounting forms of the <i>PKZ 2</i> motor and system protective circuit-breakers</b>	21
<b>Switchgear for the world market and special requirements for use in North America</b>	22
• <i>PKZ 2</i> as a motor-protective circuit-breaker for North America	23
• <i>PKZ 2</i> as a non-manual motor starter for North America	23
- High-capacity compact starters	23
- <i>PKZ2/ZM-.../S-SP</i> self-protected combination starters	23
• <i>PKZ 2</i> as a circuit-breaker for North America	25
• Insulated enclosures and accessories	25
<b>Validity of information</b>	26
<b>Bibliography</b>	26

### Motor-protective circuit-breaker or circuit-breaker?

PKZ motor-protective circuit-breakers have been manufactured by Moeller, or its predecessor Klöckner-Moeller, since 1932. The term PKZ has become so well-established in the market that specialists often even use the term for the motor-protective circuit-breakers of other suppliers. For this type of switchgear Moeller uses the term "motor-protective circuit-breaker", in accordance with its main use. For the same type of switchgear, other manufacturers use the terms "circuit-breaker" or "motor protective switch", and these terms can also generally be used for Moeller's PKZ motor-protective circuit-breaker. The applicable international standards are the circuit-breaker standard IEC / EN 60 947-2 [3], on the one hand, and the IEC / EN 60 947-4-1 [4] standard for motor protection and motor starters on the other. All PKZ(M) motor-protective circuit-breakers meet the essential requirements of a third important standard, IEC / EN 60 947-3 [5], which specifies the isolating characteristics for main switches or supply disconnecting devices, as they are currently known. In addition to the requirements of these product standards, other requirements apply from installation standards such as IEC / EN 60 204-1 [6] (Table 1) for the electrical equipment of machines. IEC / EN 60 204-1, for example, stipulates the need for suitable motor protection for virtually all types of motors, and specifies the requirements for main switches and emergency-stop devices (Table 2). It should be remembered that the current state of the art no longer automatically considers the disconnection of the main switch as the safest operating condition. Depending on the type of machine or installation involved, additional factors such as "Stopping in an emergency", "Power-off in an emergency", "Starting in an emergency", "Power-on in an emergency" [7] need to be considered.

### Motor or system protection

The title of this section indicates that these major areas of application are

Requirement	Relevant standard
Properties of motor-protective circuit-breakers	IEC / EN 60 947-4-1
Properties of circuit-breakers	IEC / EN 60 947-2
Isolating characteristics	IEC / EN 60 947-3
Main switch properties, properties of supply disconnecting devices	IEC / EN 60 204-1
Properties of emergency-stop devices	IEC / EN 60 204-1, IEC / EN 60 947-5-5
Motor starter properties with and without additional contactor or contact module	IEC / EN 60 947-4-1 to -3, IEC / EN 60 947-6-2
Properties of auxiliary contacts	IEC / EN 60 947-5-1 to -7

Table 1: The requirements placed on the switching and protective devices described in this technical paper are based on different product and installation standards.

IEC / EN 60 204-1 requirements	
Main switch	Main circuit – Emergency-stop switch
A manually operated main switch must be provided for each incoming supply	For certain machines ... the main switch may also function as an emergency-stop device
Protective interlocks must be used when two or several main switches are provided	
The following switchgear can be used as a main switch: <ul style="list-style-type: none"> <li>• Switch-disconnectors in accordance with IEC/EN 60 947-3</li> <li>• Switch-disconnector with auxiliary contact that causes switching devices to disconnect the load before the opening of the switch-disconnector main contacts</li> <li>• Circuit-breakers in accordance with IEC/EN 60 947-2, suitable for isolation in accordance with IEC / EN 60 947-3</li> </ul>	Operating elements for emergency-stop devices must be red. If the operating element is provided with a background, this must be yellow
Must only have one ON and one OFF position. They must also be clearly marked 0 and I, a Tripped position is also permissible	If the supply disconnection device (main switch) is also to be actuated directly for disconnection in the event of an emergency, it must also be easily accessible
Visible isolating gap or position indication that cannot show OFF before all contacts are actually open	
If the main switch <b>does not</b> function as an emergency-off switch at the same time, the external operating element must not be red (black or grey recommended)	
It must be lockable in the Off position	
It must disconnect all live conductors from their power supply, in the case of TN networks, the disconnection of the N conductor is optional	
The breaking capacity must be sufficient to interrupt the current of the largest motor when stalled, together with the sum of normal running currents of all other motors and/or loads.	
Power operated circuit-breakers may be used as main switches. They must be provided with a device for manual operation; when locked in the OFF position, both manual and remote closing must be prevented	

Table 2: The motor and system protective circuit-breakers of the PKZ2 system meet the requirements of IEC / EN 60 204-1, DIN VDE 0113 "Electrical Equipment of Machines" [6] for main switches and emergency-stop switches. Abbreviated version.

different in several aspects. A basic requirement of a circuit-breaker is that it does not trip unnecessarily. For this reason, the standards define tripping limits for different applications. **Table 3** shows some key differences in the requirements placed on the use of circuit-breakers. The significance of

phase loss sensitivity is an essential difference between the applications. Whilst it is normal for different loads to be present on the individual phases of circuit-breakers used in system protection, an asymmetrical phase load in motor protection indicates a fault in the motor or the cable run to

the motor. In system protection, therefore, a switch sensitive to phase loss would be a nuisance because it would initiate unnecessary tripping on load imbalance and phase loss. In motor protection, however, this would be a useful protective function.

**Different requirements for circuit-breakers used for system or motor protection**

Feature	System protection	Motor protection
Relevant standard	IEC / EN 60 947-1 [18] IEC / EN 60 947-2 [3]	IEC / EN 60 947-1 [18] IEC / EN 60 947-4-1 [4]
Limit current range		
Ambient temperature	Manufacturer specification 40 °C (Moeller)	Standard value 20 °C
Conventional non-tripping current *) for current-dependent delayed tripping  (must not trip within 2 h **), with a load on all poles, at reference temperature)	1.05 x current setting value  **) 1 h at ≤ 63 A	1.05 x current setting value
Conventional tripping current *) for current-dependent delayed tripping  (must trip within less than 2 h **) after loading with non-tripping current)	1.30 x current setting value  **) 1 h at ≤ 63 A	1.20 x current setting value
Phase loss sensitivity  Definition: Must not trip within 2 h with:  Must trip within 2 h with:	Not stipulated  Not useful since the unbalanced phase loads are permissible and frequent in the system	permissible as an alternative,  Useful protective function since the motor phase currents should be balanced  2 poles 1.0 x current setting value, 1 pole 0.9 x current setting value  2 poles 1.15 x current setting value, 1 pole 0 x current setting value
Response value of short-circuit releases (empirical values) $I_r$ = Setting of overcurrent release	Approx. 6...10 x $I_r$	Approx. 8...14 x $I_r$
Insensitivity to starting current	Necessary in some cases	Necessary
Selectivity	Mainly necessary with several circuit- breakers connected in series	Useful
Overcurrent release	Do not have to be adjustable (are always adjustable on PKZ, NZM and IZM)	Adjustable
Tripping classes	Not stipulated	Useful, for adapting to the startup behaviour of the motor
Thermal memory	Useful	Absolutely necessary

**Table 3: Different requirements for the two high volume applications of the circuit-breakers, "system protection" to IEC / EN 60 947-2 [3] and "motor protection" to IEC / EN 60 947-4-1 [4].**

\*) Terms are meaningful but are only used in IEC / EN 60 947-2

\*\*) see in second column

**Operating limits of 3-pole thermal overload relays (or motor-protective circuit-breakers) with only a 2-pole load**

Type of thermal overload relay (motor-protective circuit-breaker)		Multiple of current setting		Reference ambient temperature
		Value A (must not trip) t > 2 h, starting from cold	Value B (must trip) t ≤ 2 h	
Temperature compensated, not phase loss sensitive	3 poles	1.0	2 poles 1 pole	+ 20 °C 0
Not temperature-compensated, not phase loss sensitive	3 poles	1.0	2 poles 1 pole	+ 40 °C 0
Applicable to PKZ 2: Temperature compensated, phase loss sensitive	2 poles	1.0	2 poles	+ 20 °C
	1 pole	0.9	1 pole	0

**Table 4: Operating limits of 3-pole thermal overload relays (or motor-protective circuit-breakers) with only a 2-pole load**

Phase loss sensitivity determines phase imbalances within the limits defined by IEC / EN 60 947-4-1 for motor protection (Motor starter standard) (Table 4). Phase loss sensitivity should especially enable faster tripping if a phase totally fails, since this causes adverse effects on certain sizes of motors. PKZ 2 devices are therefore offered as system protective circuit-breakers without phase loss sensitivity and motor-protective circuit-breakers with phase loss sensitivity. The phase loss sensitivity in the PKZ 2 is

implemented by means of a differential bar (Figure 2). Phase loss sensitivity should not be confused with the functions of a phase monitoring relay. These special relays enable the operation limits to be set, for example, as a degree of phase imbalance, and currents are normally set or voltages monitored. When using protective devices with phase loss sensitivity to protect single-phase or DC supplied equipment, it must be ensured that the wiring enables the symmetrical load of the current over

all three bimetals (Figure 3). The circuit-breaker standard IEC / EN 60 947-2 does not stipulate any other practice requirements since a typical circuit-breaker such as NZM would not be required for use in AC-4 applications (inching, reversing) due to its design. However, contactors or contact modules arranged downstream can be used to implement AC-4 operations in accordance with IEC / 60 947-4-1. It must therefore be ensured that the circuit-breaker can carry the typical peak currents for AC-4 operation without any premature tripping.

Whilst the motor-protective circuit-breakers always switch and protect on three poles, in system protection (protection of cables and conductors) the fourth cable may be connected and sometimes also protected. The need for 4-pole switching and protective devices for system protection varies by region, and is also still regulated in the European Union by the national standards and requirements of the relevant utility companies and mains network suppliers.

Four-pole devices in the PKZ 2 product system are designated as PKZ 24, ZM-...-PKZ24, M-...-PKZ24. The contact modules (contactors) presented later switch on three poles. However, they can also be fitted to four-pole circuit-breakers.

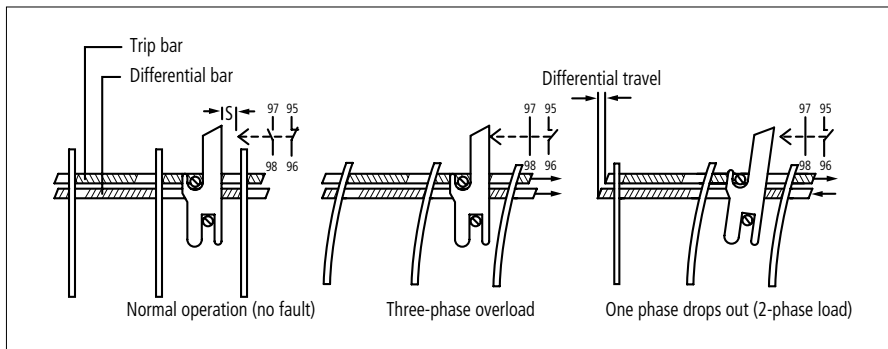

**Figure 2: Implementation of phase loss sensitivity using a design solution with a differential bar**

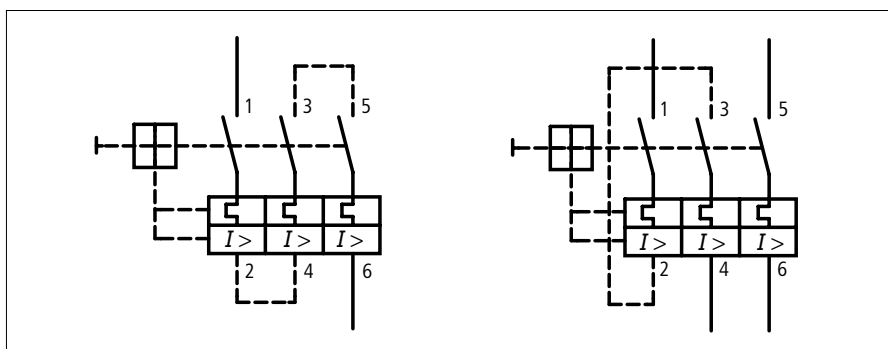

**Figure 3: All 3 bimetal strips of circuit-breakers with phase loss sensitivity must be energized with the operating current for a symmetrical load also with single-phase or DC loads**

Feature	Benefit
<ul style="list-style-type: none"> <li>• Main switch features to IEC/EN 60204-1</li> <li>• Isolating characteristics to IEC/EN 60947-3</li> <li>• Clear switch position indication for main switch and disconnecter function by means of the position of rotary handle to IEC/EN 60204-1 and IEC/EN 60947-3</li> <li>• Disconnection and isolation on all poles to IEC/EN 60204-1</li> <li>• Ability to lock or lock away handle in the Off position according to IEC/EN 60204, IEC/EN 60947-3</li> <li>• Optional red handle for emergency-stop device to IEC / EN 60204-1</li> </ul>	<ul style="list-style-type: none"> <li>• The features stated enable the circuit-breaker to also function as a main switch and/or an emergency-stop device within a motor starter. With fused motor starters these functions must be implemented if necessary with additional components.</li> </ul>
<ul style="list-style-type: none"> <li>• Indication contacts for switch position</li> <li>• Differentiated indication according to overload or short-circuit release possible</li> </ul>	<ul style="list-style-type: none"> <li>• In addition to the requirements of IEC / EN 60204-1 for the electrical equipment of machines, functions can also be implemented that allow fast detection of faults and selective fault indication. This enables machines or plants to be restored to operational readiness more quickly.</li> </ul>
<ul style="list-style-type: none"> <li>• Remote tripping by means of undervoltage or shunt releases</li> </ul>	<ul style="list-style-type: none"> <li>• In addition to standards requirements, safe remote disconnection is also possible and permitted.</li> </ul>
<ul style="list-style-type: none"> <li>• Tripping in the event of undervoltage by means of undervoltage release possible</li> </ul>	<ul style="list-style-type: none"> <li>• Undervoltage tripping prevents undefined switching states or different drop-out voltages, components susceptible to undervoltage are protected.</li> <li>• Automatic restart of motors is prevented by mechanical means (IEC / EN 60204-1).</li> </ul>
<ul style="list-style-type: none"> <li>• Manual operation outside of enclosure possible</li> </ul>	<ul style="list-style-type: none"> <li>• Operation by unskilled persons possible.</li> </ul>
<ul style="list-style-type: none"> <li>• High short-circuit breaking capacity according to IEC/EN 60947-2</li> <li>• In large setting ranges inherently short-circuit proof up to <math>I_{cu} = 100</math> to 150 kA</li> <li>• Increased switching capacity with the higher ranges using the <i>CL-PKZ2</i> current limiter</li> </ul>	<ul style="list-style-type: none"> <li>• Types that are inherently short-circuit-proof protect themselves. They do not require an upstream protective device (backup protection). This simplifies engineering, reduces costs and saves space in the control panel. The current limiter enables all setting ranges to have the same high switching capacity. This simplifies engineering and provides a consistently high level of protection. The <i>CL-PKZ2</i> current limiter can be used for individual or group protection.</li> </ul>
<ul style="list-style-type: none"> <li>• Motor switching capacity to AC-3 up to 690 V to IEC/EN 60947-4-1</li> <li>• <i>PKZ2/ZM</i>-. basic unit can be used as motor starter for type "2" coordination in accordance with IEC / EN 60947-4-1</li> </ul>	<ul style="list-style-type: none"> <li>• The features enable the circuit-breaker to be used also on its own as a motor starter.</li> </ul>
<ul style="list-style-type: none"> <li>• Overload protective function in the same device as short-circuit protection</li> </ul>	<ul style="list-style-type: none"> <li>• The circuit-breaker provides the overload and short-circuit protection function for the cables.</li> </ul>
<ul style="list-style-type: none"> <li>• Phase loss sensitivity to IEC/EN 60947-4-1</li> </ul>	<ul style="list-style-type: none"> <li>• The loss of one phase causes the overload releases to trip and can be indicated via the auxiliary contacts. Effective protection is thus ensured against the consequences of phase failure.</li> <li>• EEx motors can also be protected and switched once tripping characteristics have been compared.</li> </ul>
<ul style="list-style-type: none"> <li>• Response value of short-circuit releases approx. <math>14 \times I_e</math> (max. setting), approx. <math>22 \times I_e</math> (min. setting)</li> </ul>	<ul style="list-style-type: none"> <li>• High response values of the instantaneous trip cover also AC-4 currents and the inrush current peaks of the motors.</li> </ul>

**Table 5: Features and benefits of fuseless motor starters resulting from the use of *PKZ2/ZM*-. motor-protective circuit-breaker compared to fused motor starters. The stated standards require the feature concerned. Many features are not possible with fuses or only with additional components.**

### Motor-protective circuit-breakers in an individual enclosure, the smallest switchgear assembly

PKZ motor-protective circuit-breakers have a special importance in the field of motor protection since they function effectively as motor starters for fuseless motor protection, both as a single basic units and in conjunction with contactors or contact modules.

**Table 5** show the benefits of fuseless motor starters. PKZ motor-protective circuit-breakers belong to the group of delayed current-dependent and thermal overload protection devices as classified by IEC/EN 60947-4-1. Motor-protective circuit-breakers also feature magnetically operated instantaneous releases for short-circuit protection. Current-dependent releases are available in variants that shall be described later. These protective devices are ambient temperature compensated and are also phase loss sensitive. **Table 6** lists the range of features and functions of these highly versatile devices. On elementary machines with only one motor, all switching and protection functions, as well as main switch and emergency-stop functions can be implemented economically with only one device (**Figure 4**). **Figure 5** indicates the permissible mounting positions of the PKZ 2, including accessories.



**Figure 4:** Small switchgear assembly with the PKZ 2 motor-protective circuit-breaker providing all switching and protective functions on a simple machine, including main switch and emergency-stop function.

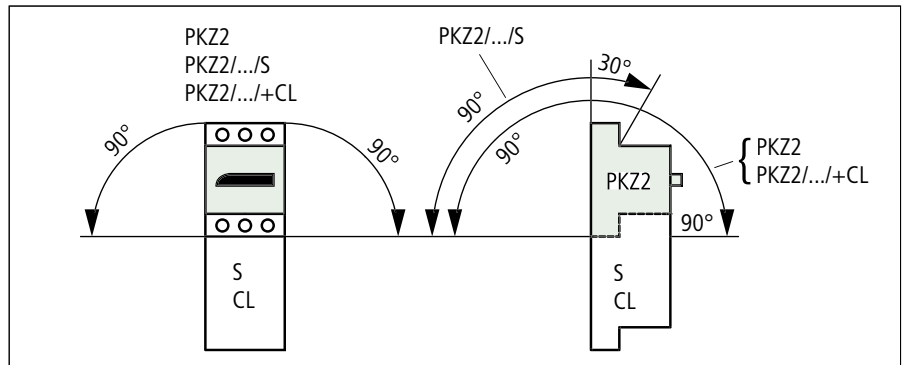

**Figure 5:** Permissible mounting positions of the PKZ 2 motor and system protective circuit-breaker including accessories such as auxiliary contact, voltage release, remote operators and contact modules.

### Various features and functions that make motor-protective circuit-breakers versatile switching and protective devices

#### Basic features of the PKZ 2 motor-protective circuit-breaker

- Circuit-breakers optimised for motor protection
- Isolating characteristics to IEC/EN 60 204-1
- Positive opening disconnection to IEC / 60 204-1
- Trip-free release
- Manual, operational switching
- Motor switching capacity to AC-3 up to 690 V to IEC/EN 60 947-4-1
- Clear switch position indication
- Current-dependent, inherently short-circuit proof self protection up to 100 kA possible
- With large rated currents, self protection as required up to 50 kA at 400 V or group protection for several circuit-breakers
- Personnel protection by means of isolating and fast tripping on all poles
- Variable short-circuit protection equally for cables and equipment
- Variable overload protection equally for cables and equipment
- For rated currents up to 40 A, i.e. for around 80 % of all three-phase motors
- Also very suitable for switching and protecting resistive loads
- Fast continuity of service after fault rectification
- Devices for world markets with all the necessary approvals and certificates

#### Optional functions of the PKZ 2 motor-protective circuit-breakers

- With phase loss sensitivity suitable for protection of EExe motors, with approval to ATEX 100a [8, 9]
- Use as main switch or main current emergency-stop switch
- Disconnection of the emergency-stop circuit possible by means of early-break auxiliary contact
- Contact modules for frequent operational switching
- Mounting and encapsulation with high degree of protection
- Occasional remote tripping
- Remote on and off switching of the circuit-breaker
- Protection against automatic restart by means of undervoltage release
- Versatile locking facility
- Versatile and differentiated status indication up to the networkable solution
- Control of higher short-circuit currents with current limiter
- Wide range of system accessories

Also as 3-pole or 4-pole system protective circuit-breaker without phase loss sensitivity available with the same system accessories.

**Table 6:** Design features that make motor-protective circuit-breakers versatile switching and protective devices.

### Occasional operational switching

The switch mechanism is a central element of the protective device and provides the bistable switching behaviour. The switch mechanism is used by the overcurrent and short-circuit releases as well as by the voltage-dependent releases to open the circuit-breaker contacts. It is connected to a rotary drive for manual operation. Different rotary handles and door coupling handles are available for this rotary drive, and the rotary handles are in part the inherent components of the flush-mounted and surface-mounted insulated enclosures (Table 7). These thumb-grip handles and similar components enable the motor-protective circuit-breaker to be used for operational switching independently of the current. At the

same time they provide a reliable means of personnel protection by providing a locking facility using padlocks. Mounting forms with the insulated enclosures mentioned and combined with door coupling handles (Figure 6) are ideal for operational switching together with additional protection from IP 54 to IP 65. These enclosures enable optimum adaption to harsh environmental conditions in the field.

### Occasional switching with remote operators

Motor-protective circuit-breakers are normally used as manually operated switches. However, the PKZ 2 motor-protective circuit-breaker is an exception to this, since the system also

features optional remote operators for remote on/off switching. Remote operators can be used for operational switching or for switching off and on after any type of trip (remote reset), as shown in Figure 7. The remote operators enable the system to be used for unique applications, such as when the switches are mounted in inaccessible tap-off units on power distribution systems. By "occasional switching" is meant that the remote operators were developed for 50 000 operations at a maximum switching frequency of 60 ops/hour.

If an AGM2-11-PKZ2 trip-indicating auxiliary contact is also used for fault indication, the associated short-circuit indicator K-AGM-PKZ2 first has to be reset manually on the circuit-breaker after a short-circuit release.

Handle features in the PKZ 2 system					
	Colour	Degree of protection	Lockable	Trip indication	Extension shaft
PKZ2 basic unit	black	Front IP 20	yes	yes	-
Flush mounting enclosure E-PKZ2	black	Front IP 41	yes	yes	-
Surface mounting enclosure CI19EA-PKZ2	black	IP 40	yes	yes	-
Surface mounting enclosure CI19EB-PKZ2 plus handle H-PKZ2 plus handle RH-PKZ2	black red/yellow	IP 54 IP 54	yes yes	yes yes	- -
Surface mounting enclosure CI19ED-PKZ24 plus handle H-PKZ2 plus handle RH-PKZ2	black red/yellow	IP 54 IP 54	yes yes	yes yes	- -
Surface mounting enclosure for CI23EA-PKZ2 compact and high-capacity compact starter	black	IP 40	yes	yes	-
Surface mounting enclosure for compact and high-capacity compact starter CI23EB-PKZ2 plus handle H-PKZ2 plus handle RH-PKZ2	black red/yellow	IP 54 IP 54	yes yes	yes yes	- -
Flush mounting enclosure E54-PKZ2 plus handle H-PKZ2 plus handle RH-PKZ2	black red/yellow	Front IP 54 Front IP 54	yes yes	yes yes	- -
Door coupling handle H-PKZ2 RH-PKZ2	black red/yellow	IP 65 IP 65	yes yes	yes yes	yes, with A-H-PKZ2 yes, with A-H-PKZ2
Door coupling handle for MCC board H-PKZ2-MCC RH-PKZ2-MCC	black red/yellow	IP 65 IP 65	yes yes	yes yes	yes, with A-H-PKZ2 yes, with A-H-PKZ2

Table 7: Extensive range of handles for PKZ 2 motor and system protective circuit-breakers with different features depending on enclosure mounting type.

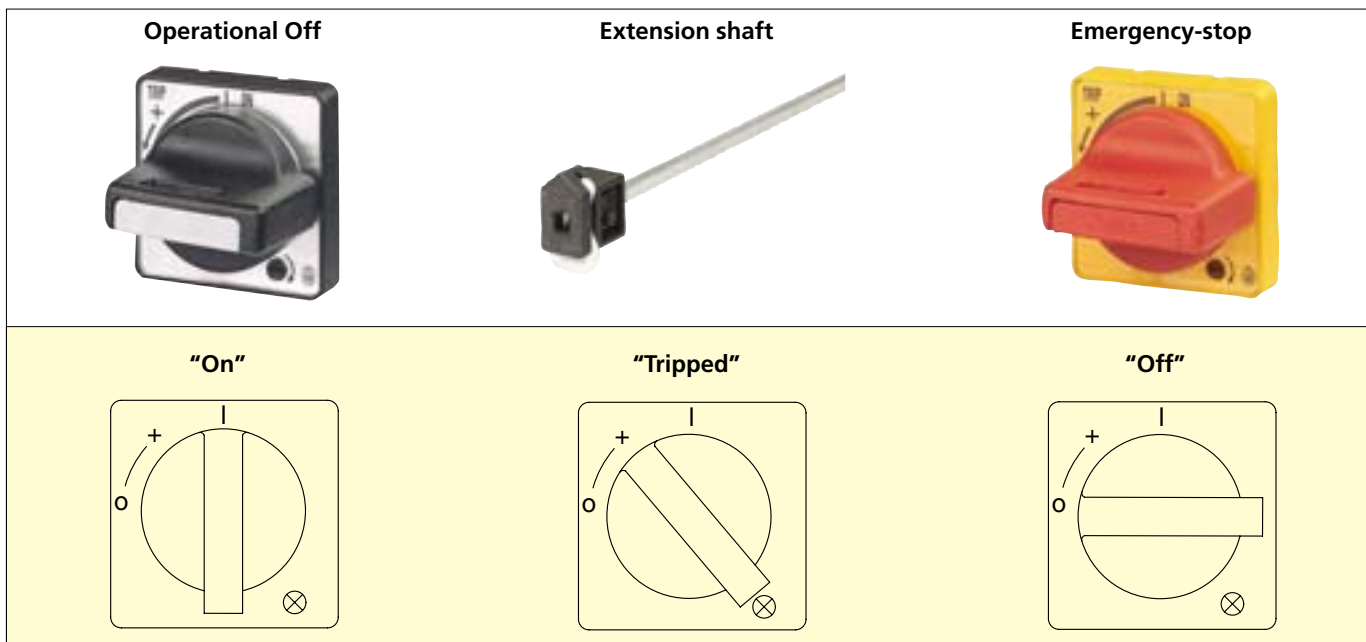

Figure 6: When the PKZ 2 motor and system protective circuit-breakers are mounted, they are actuated with the lockable H-PKZ2 (black) or RH-PKZ2 (red-yellow) door coupling handles. The handles are designed with a high level of protection to IP 65. The H-PKZ2-MCC and RH-PKZ2-MCC variants are used for mounting in MCC panels with the switches turned through 90° to the left. All handles indicate the tripping of the circuit-breaker by any release in addition to the On and Off positions.

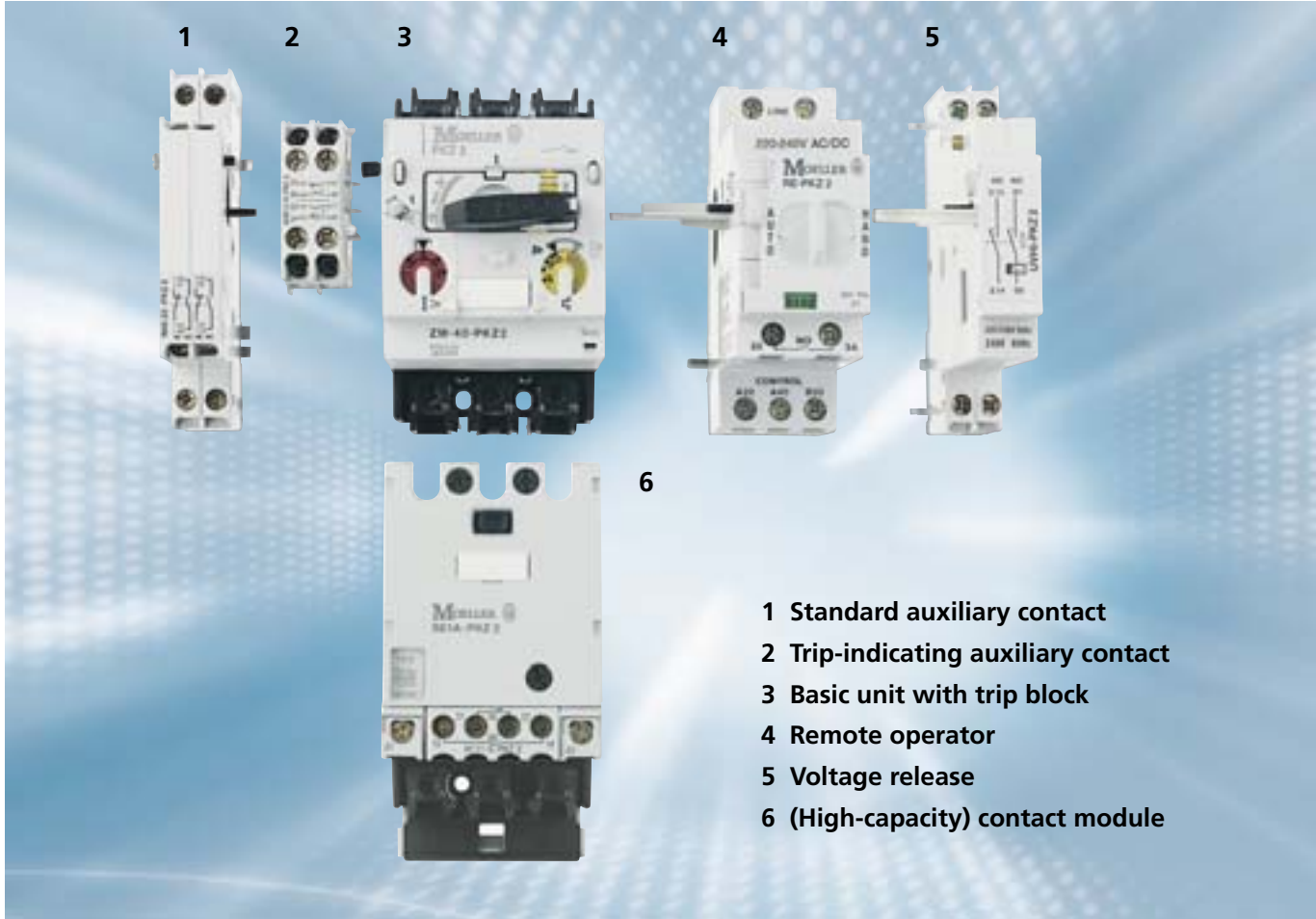
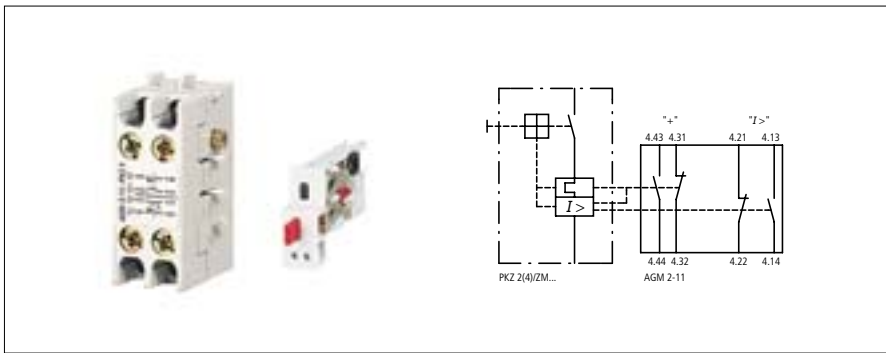

Figure 7: RE-PKZ2 or RS-PKZ2 remote operators enable the PKZ 2 motor or system protective circuit-breaker to be switched on and off remotely for operational switching. After any kind of fault the circuit-breaker can be remotely reset to service. Contact modules and high-capacity contact modules can be added to the combination for frequent operational switching.



**Figure 8:** AGM2-11-PKZ2 trip-indicating auxiliary contacts enable differentiated fault indication of the cause of tripping. With remote operators it must be remembered that the short-circuit indication contact must be reset manually for safety reasons before the circuit-breaker is switched on remotely.

The short-circuit in an installation or on a machine normally counts as a serious fault that requires the intervention of qualified electrical personnel. A specialist is normally required to assess the damage on site, rectify the fault and reset the indication contact. The trip-indicating auxiliary contact is provided with two pairs of contacts, each with 1 make contact and 1 break contact. One contact pair indicates normally that the circuit-breaker is in the tripped position (**Figure 8**). The second contact pair is specially assigned to indicating each short-circuit release. The trip-indicating auxiliary contact obtains its "information" from the mechanical short-circuit indicator. Evaluating this useful information enables system downtimes to be kept to a minimum because it is possible to assess quickly whether the fault is electrical or mechanical. Different maintenance personnel are often required depending on the type of malfunction present.

For example, the remote operators enable circuit-breakers to be switched off for maintenance work in the field and locked with a padlock (manual position / green marking). This position prevents the possibility of any further remote switch operations. Readiness for remote operation can be indicated with an integrated auxiliary contact and processed in a switching circuit (the make contact 33 / 34 is open when the remote operator is locked and closed when remote operation / red marking is possible).

The remote operators are available with AC or DC actuation and for different rated voltages. All remote operators are normally provided with a low-power logic input (Control) and a connection for an additional voltage supply (Line) that supplies the actual working current for the operator. For every switching operation, all remote operators require a supply output of 700 W / VA at the inputs 72 / 74. The logic inputs enable the switch operations to be initiated using control circuit devices that do not have to be specially designed for switching high supply outputs. With the RE-PKZ2 remote operators, the logic and supply inputs must use the same voltage potential. The special RS-PKZ2 type remote operator is ideal for actuation directly from electronic systems with semiconductor outputs without the need for any additional coupling relays. With this type, the inputs for

the logic and the supply voltage are electrically isolated so that a higher voltage from a different mains supply, such as 230 V, 50 Hz, can be used for the supply output. This configuration is useful when a drive output of 700 W / VA is required, because it is more economical to provide a higher AC voltage than a low DC voltage, which would then require a higher current. This solution is also more effective in terms of the cable cross sections required and the voltage drop present. The increased creepage and clearance distances for "safe isolation" between dangerous touch voltages and safety extra-low voltages (SELV) have been implemented between the logic inputs (Control) and the supply inputs (Line).

The RE-PKZ2 and RS-PKZ2 remote operators can also be used in conjunction with the contact modules (contactors) with compact and high-capacity compact starters. Actuation can be implemented with three-wire control or two-wire control. The minimum actuation times must be observed as shown in **Figure 9**. Circuit-breakers with remote operators cannot be combined with door coupling handles at the same time, however, they can be combined with auxiliary contacts, undervoltage and shunt releases. An NHI-PKZ2 standard auxiliary contact is always required for combinations with remote operators.

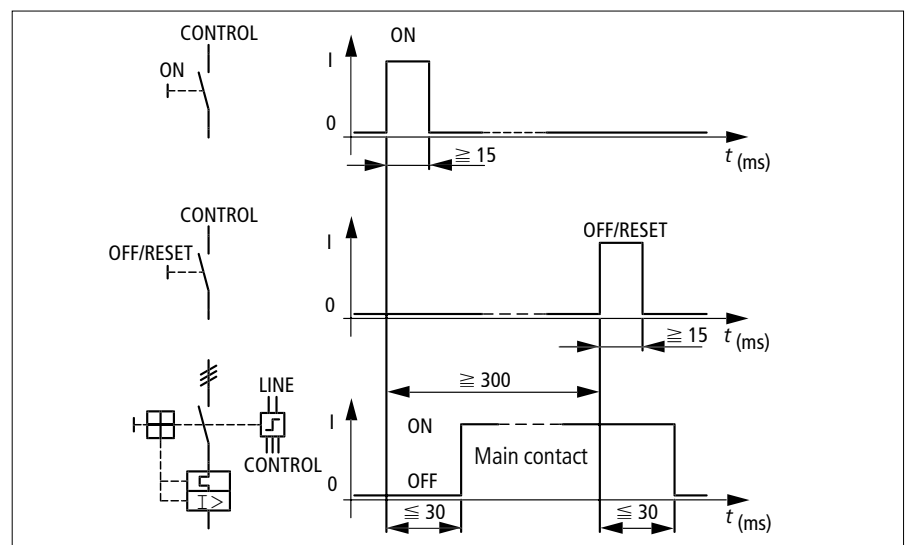

**Figure 9:** The diagram shows the minimum command duration of the RE-PKZ2 and RS-PKZ2 remote operators.

## Overload protection

Overload protection (overcurrent protection) is one of the two protective functions of the motor-protective circuit-breaker (Figure 10). The regulations define an overload as the time/current relationship in excess of the rated full load of the undamaged circuit. The overload protection should protect the motor from:

- destruction during startup or in the event of a blocked rotor
- impermissible reduction of lifespan while running due to excessive winding temperatures,

This protective function is implemented by the current of the equipment flowing directly across the bimetal strips or a heating coil on the bimetal contacts. The bimetal strips bend in proportion to the level of current present. If the response current  $I_r$  set on the circuit-breaker is exceeded for the time determined by the tripping characteristics, this causes the bending required to trip the switch mechanism of the circuit-breaker. The necessary operation limits of overload releases are specified in IEC/EN 60947-4-1. Motor-protective circuit-breakers are normally set to the rated motor current (rating plate). Unlike motor protective relays, motor-protective circuit-breakers or circuit-breakers are also connected in star-delta combinations in the supply conductor, so that the rated motor current must also be set here. Particular features must be taken into account when setting the motor protective relay, depending on the different possible arrangements of the protective device. They are mostly set to the phase current.

The bimetal strips do not cool down immediately after the current load is removed by the trip, neither do they return to their original position immediately. They cool down according to specific characteristic curves that essentially follow the cooling characteristics of the motor concerned. This effect is known as the thermal memory, and takes into account the preloading of the consumer when it is switched on

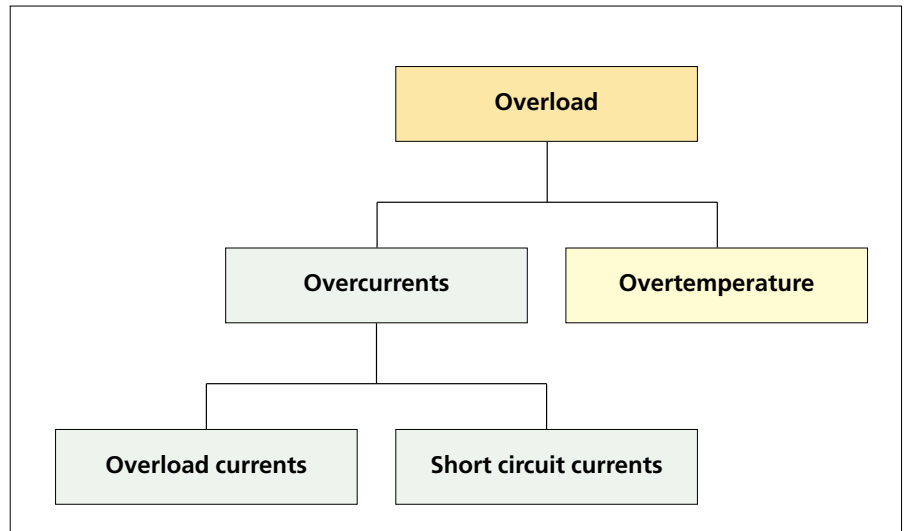

Figure 10: Hierarchy of concepts related to overload. Overtemperatures can also be considered as an overload. With current-dependent protective devices, it is more precise to speak of overload currents and short-circuit currents.

again within a short time. The tripping time at operational temperature is reduced to  $\frac{1}{4}$  of the time required with the motor-protective circuit-breaker and motor in a cold state. Figure 11 shows the average tripping characteristics of a PKZ 2/ZM-.. motor-protective circuit-breaker used for motor protection and a PKZ2/ZM-...-8 used for system protection.

When used together with the PKZ 2 basic units, certain trip blocks such as ZM-..-PKZ2 or ZMR-..-PKZ2, with overload protection and phase loss sensitivity (see also "Motor or system protection"), are suitable and approved for the protection of EEXe motors when used in accordance with

the specifications of the Main Catalogue and the manual [8]. The approval is based on ATEX 100a [9] and is marked on the devices. Trip blocks without overload protection (M-...-PKZ2) by definition are not suitable for this task.

## Short-circuit protection

Short-circuit protection is the second function of motor-protective circuit-breakers. Short-circuit currents are impermissible overcurrents that overload and damage all elements of the circuit (switching and protective device, cables and equipment). The short-circuit currents create highly

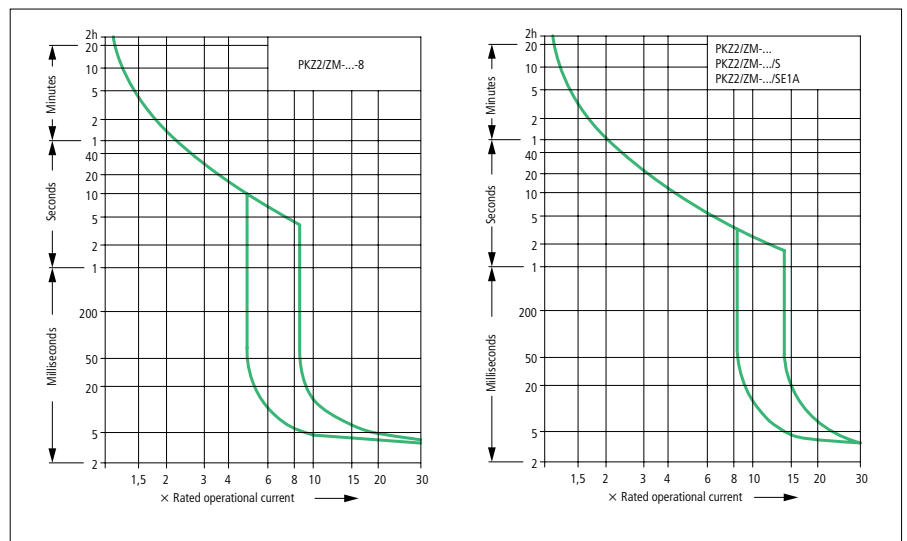

Figure 11: Examples of the tripping characteristics of a PKZ2/ZM-.. (right) for motor protection and a PKZ2/ZM-...-8 (left) for system protection.

dynamic stresses, and the forces produced are proportional to the square of the current present. If the short-circuit protection provided is insufficient, the installation may explode with dangerous arcing effects. The maximum short-circuit current is roughly based on the specific short-circuit capacity of the supply network (Table 8). Long cable lengths (inductive loads) and current limiting protective devices that are interconnected can reduce the possible theoretical values. In uncertain cases, a short-circuit calculation should be carried out.

For example, the permissible temporary overload range of PKZ2/ZM-.. motor-protective circuit-breakers is between  $> 1.05$  and  $\leq 8 \dots 14 \times I_e$ . Currents above this defined overload range (e.g.  $> 14 \times I_e$ ) are short-circuit currents. The deflection of the bimetals is far too slow for detecting these impermissible short-

circuit currents which must be disconnected very quickly due to the dynamic effects described. In every phase (cable) of the motor-protective circuit-breakers, an electromagnetic instantaneous release is therefore connected in series in addition to the bimetal release. The short-circuit release represents virtually the emergency brake for currents that can no longer be controlled safely in the circuit.

On PKZ2/ZM-.. motor-protective circuit-breakers the operating limits were set very high in order to ensure that motors with high peak starting currents could be switched on reliably without tripping the circuit-breaker unnecessarily. The response values are based on the upper current setting value  $I_r$  of the overload release. If currents are set that are lower than the maximum value on the overload release, the ratio to the response value of the short-circuit release is even

higher and the risk of unnecessary tripping is even lower. An essential feature of the PKZ 2 motor-protective circuit-breaker system is the fact that these switches also allow the operation limit for the short-circuit releases to be set. Table 9 shows the available range.

#### Inherent stability

On motor-protective circuit-breakers, the main contacts, the overcurrent bimetal releases and the short-circuit releases are all connected in series on each phase. The lower the rated uninterrupted current  $I_u$  of a motor-protective circuit-breaker, the higher the resistive load of its bimetal coil. With motor-protective circuit-breakers for small currents, this resistive load restricts the short-circuit current so severely that the circuit-breaker cannot be damaged. Motor-protective circuit-breakers with low rated uninterrupted currents  $I_u$  are therefore considered to be inherently short-circuit proof, i.e. they can

**Short-circuit currents of standard transformers**

Rating kVA	400 V			500 V			690 V		
	Rated current A	Short-circuit voltage $u_k$		Rated current A	Short-circuit voltage $u_k$		Rated current A	Short-circuit voltage $u_k$	
		4 % <sup>1</sup>	6 % <sup>2</sup>		4 % <sup>1</sup>	6 % <sup>2</sup>		4 % <sup>1</sup>	6 % <sup>2</sup>
		Short-circuit current $I_k''^3$			Short-circuit current $I_k''^3$			Short-circuit current $I_k''^3$	
		kA	kA		kA	kA		kA	kA
50	72	1.80	1.20	58	1.44	0.96	42	1.05	0.70
100	144	3.61	2.41	116	2.89	1.93	84	2.09	1.40
160	231	5.77	3.85	185	4.62	3.08	134	3.35	2.23
200	289	7.22	4.81	231	5.78	3.85	167	4.19	2.79
250	361	9.02	6.01	289	7.22	4.81	209	5.23	3.49
315	455	11.36	7.58	364	9.10	6.06	264	6.59	4.39
400	577	14.43	9.62	462	11.55	7.70	335	8.37	5.58
500	722	18.04	12.03	578	14.44	9.63	419	10.46	6.98
630	909	22.73	15.15	728	18.19	12.13	527	13.18	8.79
800	1154	28.86	19.24	924	23.10	15.40	670	16.74	11.16
1000	1143	36.08	24.05	1155	28.88	19.25	837	20.93	13.95
1250	1804	45.09	30.06	1444	36.09	24.06	1046	26.16	17.44
1600	2309	57.72	38.48	1848	46.20	30.80	1339	33.48	22.32
2000	2886	72.15	48.10	2310	57.75	38.50	1674	41.85	27.90

Table 8: Rated currents and short-circuit currents of standard transformers

<sup>1</sup>  $u_k = 4 \%$ , standardised to DIN 42 503 for  $S_{NT} = 50 \dots 630$  kVA

<sup>2</sup>  $u_k = 6 \%$ , standardised to DIN 42 511 for  $S_{NT} = 100 \dots 1600$  kVA

<sup>3</sup>  $I_k''$  = Transformer initial short-circuit AC current on connection to mains supply with unlimited short-circuit capacity

Features of the variants in the PKZ 2 product system					
Feature	Motor-protective circuit-breakers		System protective circuit-breaker		Short-circuit protective device
		With overload relay function	With overload release	Without overload release	*)
	PKZ2/ZM-...	PKZ2/ZMR-...	PKZ2/ZM-...-8	PKZ2/M-...-8	PKZ2/M-...
Max. rated uninterrupted current $I_u$	40 A	40 A	40 A	40 A	40 A
Number of contacts	3	3	3 or 4	3 or 4	3
Overload protection	yes, plug-in type	yes, plug-in type	yes, plug-in type	-	-
Phase loss sensitivity	yes	yes	-	-	-
Protection of EExe motors	yes	with restrictions **)	-	-	-
Short-circuit protection Release current $I_{rm}$	Yes, pluggable, adjustable: $8.5 - 14 \times I_u$	Yes, pluggable, adjustable: $8.5 - 14 \times I_u$	Yes, pluggable, adjustable: $5 - 8.5 \times I_u$	Yes, pluggable, adjustable: $5 - 8.5 \times I_u$	Yes, pluggable, adjustable: $8.5 - 14 \times I_u$
up to $I_q = 100$ kA / 400 V inherently short-circuit proof **), for $I_u$ up to	16 A	16 A	16 A	-	-
up to $I_q = 100$ kA / 400 V inherently short-circuit proof **), with current limiter, for $I_u$ up to	40 A	40 A	40 A	-	-
Contact module Type "1" coordination, 415 V	SE1A-PKZ2 18.5 kW	SE1A-PKZ2 18.5 kW	SE1A-PKZ2 20 kW	SE1A-PKZ2 20 kW	SE1A-PKZ2 20 kW
High-capacity contact module Type "2" coordination, 415 V	S-PKZ2 18.5 kW	S-PKZ2 18.5 kW	S-PKZ2 20 kW	S-PKZ2 20 kW	S-PKZ2 20 kW

\*) Possible in combination with motor protective relay or thermistor overload relays for motor protection  
 \*\*) Observe note in Main Catalogue concerning circuit  
 \*\*\*) For other voltages see Main Catalogue

**Table 9: Features and technical data, depending on type of circuit-breaker.**

protect themselves. Contact welding cannot occur, the overload and short-circuit releases cannot be destroyed and the tripping characteristics are not altered by the short-circuit current.

Depending on the voltage, inherently short-circuit proof PKZ2/ZM-.. motor-protective circuit-breakers are suitable for coordination type "1" and "2" (Table 10) up to short-circuit currents of 100 kA (rated conditional short-circuit current  $I_q$  in accordance with motor starter standard IEC / EN 60947-4-1) (Table 9). On PKZ2/ZM-.. motor-protective circuit-breakers, the rated ultimate short-circuit breaking capacity  $I_{cu}$  and the rated service short-circuit breaking capacity  $I_{cs}$  is also 100 kA, in the range of inherent stability. For explanations of  $I_{cu}$  and  $I_{cs}$ , in accordance with the circuit-breaker standard IEC / EN 60947-2, refer to Table 11. Motor-protective

circuit-breakers are available on the market that have an inherent stability as low as 50 kA. Inherently short-circuit proof circuit-breakers do not require an additional upstream short-circuit protective device (backup protection) in IEC systems.

The inherent stability of a motor-protective circuit-breaker depends on the design features of the circuit-breaker as well as the rated operational voltage. This means that inherent stability varies according to rated operational voltage and design, as well as according to the rated

Coordination types	
"1"	"2"
<ul style="list-style-type: none"> <li>The specified short-circuit current <math>I_q</math> is disconnected safely.</li> <li>No danger shall be caused to persons and installation.</li> <li>After a short-circuit disconnection the starter must be examined before further use. The contactor and/or overload relay *) must be exchanged if necessary.</li> </ul>	<ul style="list-style-type: none"> <li>The specified short-circuit current <math>I_q</math> is disconnected safely.</li> <li>No danger shall be caused to persons and installation.</li> <li>The starter should be suitable for further use after inspection without replacement of parts.</li> <li>Contact welding that can be easily separated is permissible.</li> </ul>

**Table 10: Shortened definitions of coordination types according to IEC 60 947-4-1**

\*) An overload relay is only provided in special cases for fuseless starters

Feature	Rated <i>ultimate</i> short-circuit breaking capacity $I_{cu}$	Rated <i>service</i> short-circuit breaking capacity $I_{cs}$
	Previously: P-1 to IEC 157	Previously: P-2 to IEC 157
Tested at	$U_e$ , $\cos \varphi$ dependent on the test current [kA], e.g. $6 < I \leq 10$ $\cos \varphi$ 0.5 $10 < I \leq 20$ $\cos \varphi$ 0.3 $20 < I \leq 50$ $\cos \varphi$ 0.25 $50 < I$ $\cos \varphi$ 0.2	$U_e$ , $\cos \varphi$ dependent on the test current [kA], e.g. $6 < I \leq 10$ $\cos \varphi$ 0.5 $10 < I \leq 20$ $\cos \varphi$ 0.3 $20 < I \leq 50$ $\cos \varphi$ 0.25 $50 < I$ $\cos \varphi$ 0.2
(Test sequence) switch operations	(III) O - t - CO *)	(II) O - t - CO - t - CO *)
Subsequent insulation test	With $2 \times U_e$ , at least at 1000 V	With $2 \times U_e$ , at least at 1000 V
Subsequent testing of the thermal release	The tripping time in one pole must not exceed the stated maximum	Conventional tripping time must not be exceeded
Subsequent temperature rise test	–	The overtemperatures must not exceed the limit temperature values
For utilization category A	100 %	Standard: 25 - 50 - 75 - 100 % of $I_{cu}$
For utilization category B	100 %	Standard: 50 - 75 - 100 % of $I_{cu}$

**Table 11: Differences between the rated ultimate short-circuit breaking capacity  $I_{cu}$  and the rated service short-circuit breaking capacity  $I_{cs}$  according to IEC/EN 60 947-2**  
Key \*: O = Open; t = time interval; CO = Close and Open

uninterrupted current  $I_u$  of the motor-protective circuit-breaker concerned. The Moeller HPL main catalogue provides full information on inherent stability in relation to different rated operational voltages, and **Table 12** provides an extract of this.

For protective circuit-breakers that cannot provide inherent stability up to 100 kA with high rated operational voltages, **Table 12** shows the maximum short-circuit currents for which upstream fuse protection (backup protection) is not required. Additional measures are necessary if these short-circuit currents are exceeded in the event of a fault. These can be larger upstream *NZM* circuit-breakers, the current limiters described later, the high-capacity contact modules, or if necessary, upstream fuses in the specified size. The first three options offer the benefits of a fuseless solution.

#### Controlling particularly high short-circuit currents with *CL-PKZ2* current limiters

Not all setting ranges could be developed with inherent stability in the *PKZ2* system due to the physical characteristics of the releases. The three major ranges of -25 A, -32 A and 40 A on their own each have a rated ultimate limit short-circuit breaking capacity  $I_{cu}$  of 30 kA at 400 V. If higher short-circuit currents are expected, an additional protective device must be connected upstream to protect the motor-protective circuit-breaker from the effects of the short-circuit. With fuseless motor starters, an *NZM* circuit-breaker is used which ideally also takes over the function of the main switch for the system. In many applications it is also possible to use a circuit-breaker for the group protection of several motor starters, such as for a distribution panel.

Alternatively, 160 A fuses can also be used to provide backup protection.

Another effective solution is the use of the *CL-PKZ2* current limiter. Together with this module all setting ranges of the *PKZ 2* are inherently short-circuit proof at 400V. The resulting effect of current limiters is called current limitation. **Figure 12** shows the current characteristics of a single *PKZ 2* and the current characteristics of the *PKZ 2* in combination with the *CL-PKZ2* or the equivalent *S-PKZ2* high-capacity contact module that will be presented later. The poles of the current limiter and the motor-protective circuit-breaker are connected in series. The current limiter features a contact element consisting of three independent repulsion contacts that are closed in normal operation. The fixed contact is formed as a current loop. In the event of a fault, the short-circuit current present

Switching capacity of the motor and system protective circuit-breakers and the high-capacity compact starters												
$I_u$ A	400 V				500 V				690 V			
	$I_q$ kA	$I_{cu}$ kA	$I_{cs}$ kA	gG/gL* A	$I_q$ kA	$I_{cu}$ kA	$I_{cs}$ kA	gG/gL* A	$I_q$ kA	$I_{cu}$ kA	$I_{cs}$ kA	gG/gL* A
<i>PKZ2/ZM</i> with type "1" and "2" coordination												
0.16 – 1.6				N				N				N
2.4				N				N				N
4				N				N	4.5	4.5	2.5	63
6				N				N	4.5	4.5	2.5	80
10			30	N	7	7	3.5	80	4.5	4.5	2.5	80
16			30	N	7	7	3.5	100	4.5	4.5	2.5	100
25	30	30	7.5	160	7	7	3.5	125	4.5	4.5	2.5	125
32	30	30	7.5	160	7	7	3.5	160	4.5	4.5	2.5	160
40	30	30	7.5	160	7	7	3.5	160	4.5	4.5	2.5	160
<i>PKZ2/ZM + CL-PKZ2</i> with type "1" and "2" coordination												
0.16 – 1.6				N				N				N
2.4				N				N				N
4				N				N	10	4.5	2.5	N
6				N				N	10	4.5	2.5	N
10			30	N			3.5	N	10	4.5	2.5	N
16			30	N			3.5	N	10	4.5	2.5	N
25			7.5	N			3.5	N	10	4.5	2.5	N
32			7.5	N			3.5	N	10	4.5	2.5	N
40			7.5	N			3.5	N	10	4.5	2.5	N
<i>PKZ2/ZM-.../S(-G)</i> with type "1" and "2" coordination												
0.6 – 2.4		N	N			N	N			N	N	
4 - 6		N	N			N	N		10	N	N	80
10 - 16		N	N			N	N		10	N	N	100
25 - 40		N	N			N	N		10	N	N	160
<i>PKZ2/ZM-...-8/S(-G)</i>												
0.6 – 2.4	N			N	N			N	N			N
4 - 6	N			N	N			N	N	10	5	80
10 - 16	N			N	N			N	N	10	5	100
25 - 40	N			N	N			N	N	10	5	160
Key:	■ = Inherently short-circuit proof range (100 kA)						N = Not required					

**Table 12:** Switching capacities of motor and system protective circuit-breakers and high-capacity compact starters and any backup protective devices required depending on operational voltage.

generates magnetic fields with the same polarity in the current loop of the fixed contact and around the moving contact, thus forcing them to repel each other (Figure 13). The dynamic effect of these fields forces the moving contacts (Figure 14) open. On the CL-PKZ 2 current limiters this movement is further supported by means of striking armatures that have

a similar design to the magnetic instantaneous trips with a moving armature and a magnet coil energized by the short-circuit current.

The arcs created when the contact opens form resistances that dampen the short-circuit current to non-critical values. At the same time, the magnetic instantaneous releases in the motor-

protective circuit-breaker activate the opening of its contact. The arcs they produce cause additional damping and the faulty current circuit is disconnected by the release of the switch mechanism. The repulsion contacts automatically return to their closed rest position after a current duration of approx. 4 to 7 ms. The current limiter is then operational

\* Fuse only necessary when  $I_{sc} > I_q$

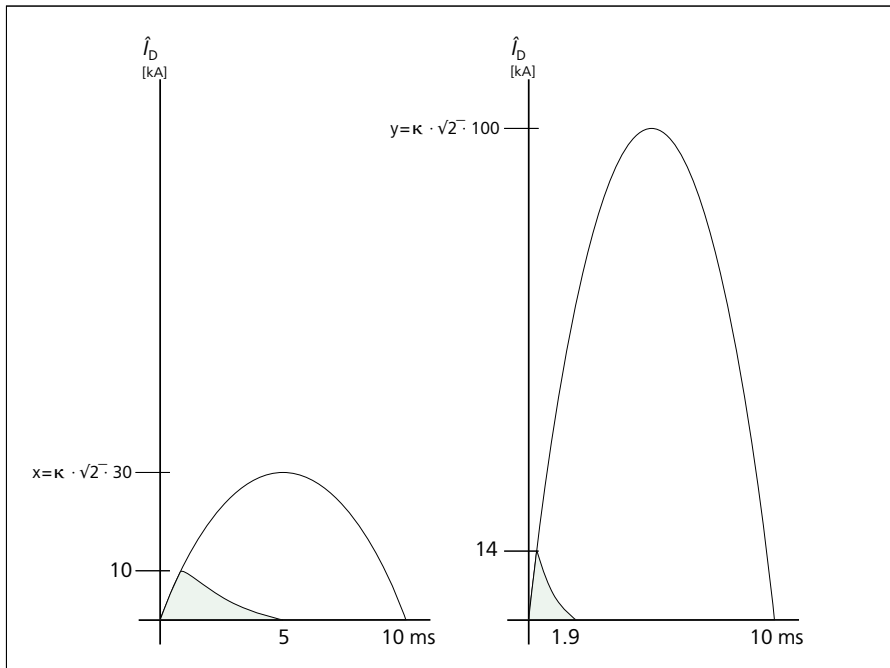

Figure 12: Current limitation with a PKZ2/ZM-... or PKZ24/ZM-... motor or system protective circuit-breaker (left) and in combination with a CL-PKZ2 current limiter or a high-capacity contact module that provides equivalent current limitation. The coloured area indicates the switch energy  $I^2t$ .

again without any parts having to be exchanged.

The current limiter is rated for a continuous current of 40 A, and so group protection can also be implemented with this module (Figure 15). The smaller motor rated currents of the connected feeders are either added together up to a total of  $\leq 40$  A, or the value is calculated from the maximum setting currents of the motor-protective circuit-breakers and a diversity factor.

The current limiter is used for all rated voltages up to 690 V. It is snap fitted onto a DIN rail next to the group of

motor-protective circuit-breakers with an adapter, or the module is fitted like a contact module to a single motor-protective circuit-breaker with matching profiles (Figure 16). Three-phase commoning links (B.-PKZ2) can be used to electrically connect adjacent motor-protective circuit-breaker groups on the DIN rail to the current limiter. The current limiting capacity of the module depends on the voltage. The values for the different rated operational voltages are shown in Table 12. For really high voltages two current limiters connected in series are sometimes used together with the motor-protective circuit-breaker.

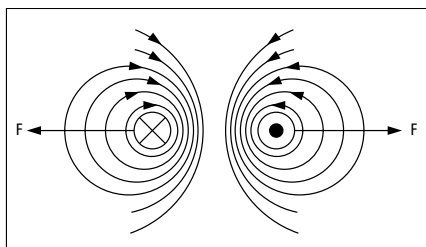

Figure 13: Force fields are formed around energized conductors that repel each other in a current loop due to the opposing current directions. This dynamic physical effect is used in the CL-PKZ2 current limiters and S-PKZ2 high-capacity contact modules

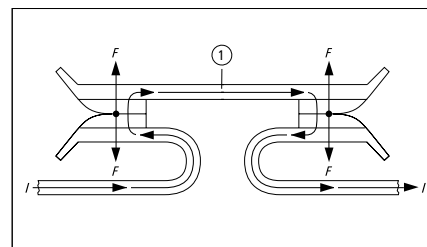

Figure 14: Diagram of the current limiting contact system on CL-PKZ2 or S-PKZ2. The repulsion force is  $F \sim I^2$ .  
① = moving contact

### Separate short-circuit protection and overload protection?

With fuse-based motor circuits, the short-circuit protection and overload protection are always provided by different protective devices. An advantage of the circuit-breaker and motor-protective circuit-breaker solutions is that these normally provide both short-circuit protection and overload protection for the entire motor feeder, thus eliminating the associated coordination, mounting and wiring requirements. Motor protection can, however, also be provided by combining a circuit-breaker without overcurrent release (PKZ2/M-..) and an additional overload relay. This configuration is used for example with motors with special startup requirements (heavy duty starting).

However, these kinds of combinations are also useful when the circuit-breaker is only required to provide short-circuit protection. In this case, the motor protective relay is required to indicate the overload and switch off the motor via a contactor without the tripping of the circuit-breaker. This kind of circuitry is used for processes where overloads frequently arise that can nevertheless be rectified automatically or by means of small interventions by operating personnel. In the PKZ 2 system, ZMR-..-PKZ2 motor protection trip blocks are offered with an overload relay function for these applications (Figure 17). In some processes drives that do not represent any particular hazard can restart automatically after the load has been removed (IEC/EN 60204-1).

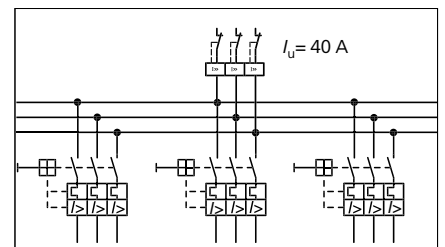

Figure 15: Example of group protection with the CL-PKZ2 current limiter. Alternatively an NZM circuit-breaker or if necessary fuses can be used instead of a current limiter.

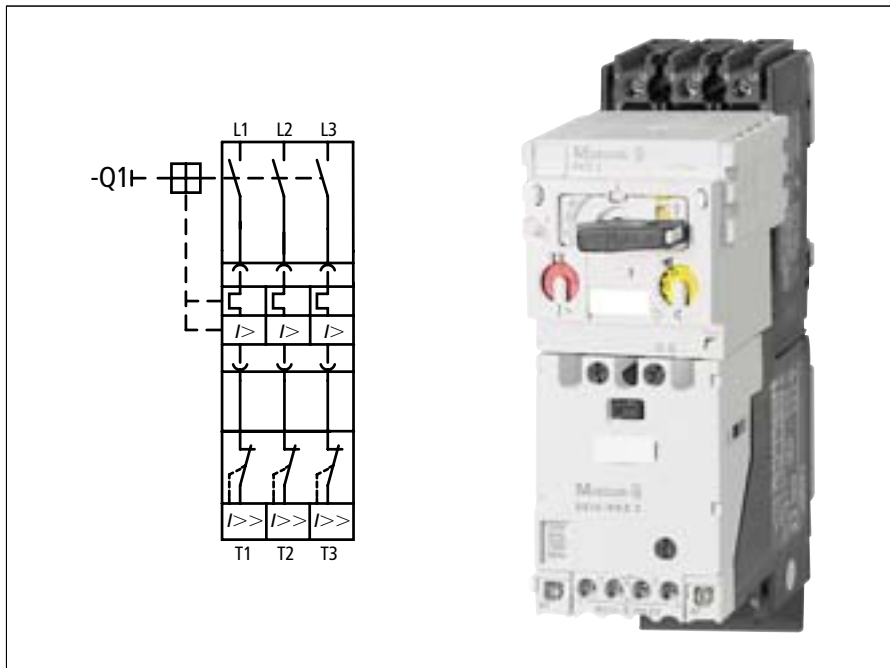

Figure 16: PKZ2/ZM- motor or system protective circuit-breaker with matching CL-PKZ2 current limiter fitted. The enclosures of the current limiters and contact modules are largely similar.

This variant requires the manual/auto selector switch to be set to Auto-Reset on the ZMR. The ZMR must be reset manually if Manual operation is set. The contactor must then be switched on again. With EEXe applications, it must always be ensured that the motor is disconnected by the contactor on overload, without Auto Reset.

The separation of short-circuit protection from overload protection is not entirely straightforward. In these kinds of applications, the circuit-breaker may be loaded with currents

that are above its rated current but below the response value of its short-circuit release. The circuit-breaker is overloaded and cannot protect itself, the cables and loads from currents in this range. In this case, another suitable means of sufficient overload protection must therefore be provided. If these higher currents are present for a long period, such as in the case of heavy duty starting with higher tripping classes, the equipment must be dimensioned for the increased thermal load [10] (Table 13).

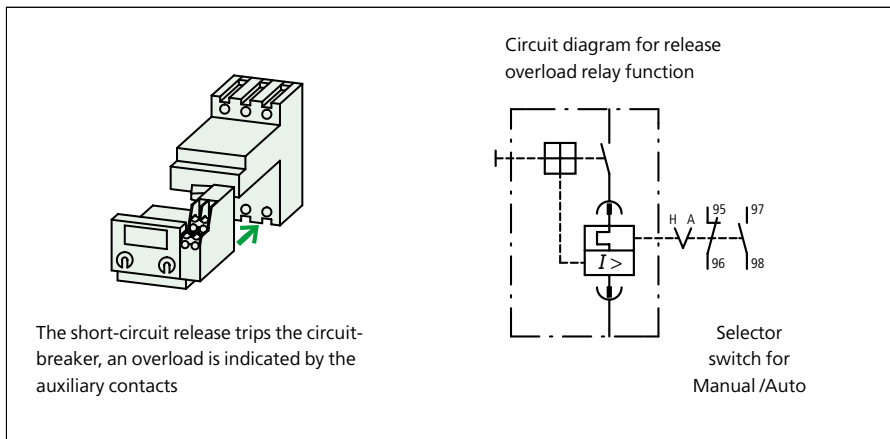

Figure 17: ZMR-...-PKZ2 motor-protective trip block with overload relay function. In the event of a short-circuit, the trip block acts on the switch mechanism and releases the circuit-breaker. The circuit-breaker is not tripped in the event of an overload. However, this is indicated by auxiliary contacts 95-96 / 97-98 on an overload relay and processed in the circuitry.

### Pluggable overcurrent and short-circuit releases

The plug-in trip blocks of the PKZ 2 system offer features over and above those commonly available on the market (Figure 18). The plug-in trip blocks are available as 3 and 4 pole versions for motor protection or system protection. The trip blocks for the ZMR-...-PKZ 2 overload relay function are also pluggable (Table 9). An interlock feature in the design ensures that the trip blocks can only be removed or fitted in a de-energized state, when the circuit-breaker is switched off.

When industrial applications are in the planning stage, the exact rating data of motors and loads is often not available. Motors with the same rating but from different manufacturers can also have different specifications. It may therefore be necessary to replace trip blocks during commissioning since motor currents are too close to their upper and lower setting limits. With other product systems it would be necessary in this case to replace the entire circuit-breaker. However, with the PKZ 2 only the trip block needs to be exchanged. The trip block can be exchanged easily when the motor-protective circuit-breaker or system protective circuit-breaker is already installed or wired. Alternatively, the trip block can just be selected and

Correction factor for lengthy overload	
CLASS	Factor
5	1.0
10	1.0
15	1.22
20	1.41
25	1.58
30	1.73
35	1.89
40	2.0

Table 13: When using M-PKZ2 as short-circuit protection for motors with heavy startup characteristics, the rated current  $I_e$  must be oversized by the stated factor when the switchgear is engineered.



















